

ARB **BASE RACK**

FITTING INSTRUCTION

Part Number(s):
17940020

Suits BASE RACK:
1770060/70

Product Description: **BASE RACK fitting kit suits:**

- **Ford Ranger 2011 On models PX, PXII & PXIII**
- **Mazda BT50 2011-2020 models UP & UR**

WARNING

REGARDING VEHICLES EQUIPPED WITH SRS AIRBAG:

When installed in accordance with these instructions, the cab rack does not affect operation of the SRS curtain airbags.

ALSO, NOTE THE FOLLOWING:

- ◆ This product must be installed exactly as per these instructions using only the hardware supplied.
- ◆ In the event of damage to any cab rack component, contact your nearest authorised ARB stockist. Repairs or modifications must not be attempted.
- ◆ Do not use this product for any vehicle make or model, other than those specified by ARB.
- ◆ Do not remove labels.
- ◆ This product or its fixing must not be modified in any way.
- ◆ The installation of this product may require the use of specialized tools and/or techniques
- ◆ It is recommended that this product is only installed by trained personnel
- ◆ These instructions are correct as at the publication date. ARB Corporation Ltd. cannot be held responsible for the impact of any changes subsequently made by the vehicle manufacturer
- ◆ During installation, it is the duty of the installer to check correct operation/clearances of all components
- ◆ Work safely at all times
- ◆ Unless otherwise instructed, tighten fasteners to specified torque

ARB 4x4 ACCESSORIES

Corporate Head Office

42-44 Garden St
Kilsyth, Victoria
AUSTRALIA 3137

Tel: +61 (3) 9761 6622
Fax: +61 (3) 9761 6807

Australian enquiries
North & South American enquiries
Other international enquiries

sales@arb.com.au
sales@arb.com.au
exports@arb.com.au

SAFETY

NET PAYLOAD FOR YOUR BASE RACK

The net payload for your BASE RACK is calculated by subtracting the weight of the BASE RACK and the vehicle mounting kit from the vehicle's roof capacity. The table below gives the BASE RACK net payload for fitting kit 17940020, using the vehicles maximum vehicle roof capacity. The vehicle's roof load capacity may vary between models and driving conditions. Refer to vehicle owner's manual for model and condition specific roof load capacities.

Kit	BASE RACK	Vehicle roof capacity* (kg/lb)	BASE RACK + mount kit (kg/lb)	BASE RACK net payload (kg/lb)
17940020	1770060	80 / 176	20 / 44	60 / 132

* Maximum roof load capacity. Refer to vehicle owner's manual for model and condition specific roof load capacities.

It is important to follow these safety instructions;

- ◆ Maximum load per BASE RACK beam is 25kg.
- ◆ Load must be evenly distributed and adequately secured.
- ◆ Any weight carried on the roof of the vehicle will adversely affect its handling, particularly in cornering or in a cross-wind, the vehicle should therefore be driven with increased discretion.
- ◆ Regularly check the tightness of the securing clamps and the security of the load.
- ◆ Attention is directed to statutory requirements regarding maximum permissible projections from vehicles.

All bolts should be checked prior to touring to ensure the tray is fastened correctly

GENERAL CARE AND MAINTENANCE

By choosing an ARB BASE RACK, you have bought a product that is one of the most sought after 4WD products in the world. Your BASE RACK is a properly engineered, reliable, quality accessory that represents excellent value. To keep your BASE RACK in original condition it is important to care and maintain it following these recommendations:

- As part of any pre-trip preparation, or on an annual basis, it is recommended that a thorough visual inspection of the BASE RACK is carried out, making sure that all bolts and other components are torqued to the correct specification. Replace any components as necessary.



Please contact local Authorised ARB Stockist if you would like to have this service carried out on your behalf.

FITTING REQUIREMENTS

REQUIRED TOOLS FOR FITMENT OF PRODUCT:

Basic tool kit	Centre punch & small hammer
Torque wrench	Metric Torx key set
9.0mm drill bit & cordless drill	Metric Allen key set

HAVE AVAILABLE THESE SAFETY ITEMS WHEN FITTING PRODUCT:





Protective eyewear	Hearing protection
	

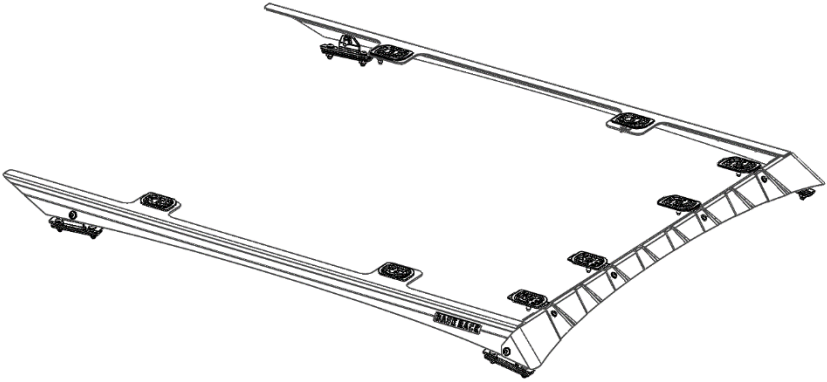

NOTE: 'WARNING' notes in the fitting procedure relate to OHS situations, where to avoid a potentially hazardous situation it is suggested that protective safety gear be worn or a safe work procedure be employed. If these notes and warnings are not heeded, injury may result.

FASTENER TORQUE SETTINGS:

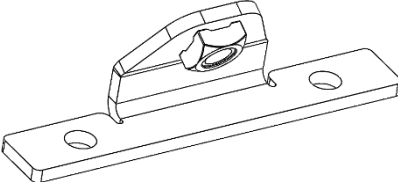
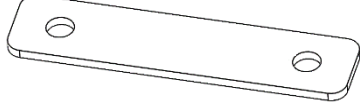
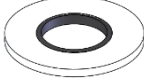
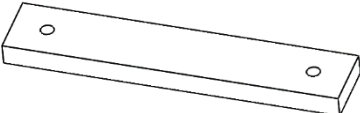
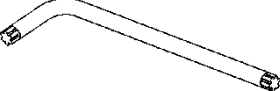
SIZE	Torque Nm	Torque lbft
M6	9Nm	7lbft
M8	22Nm	16lbft
M10	44Nm	32lbft
Seat Belt Bolts	50Nm	36lbft
M12	77Nm	57lbft

PARTS LISTING - BASE RACK fitting kit			
PART NUMBER	SUITS BASE RACK	QTY	DIAGRAM
17940020	1770060	1	

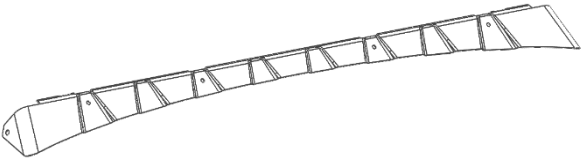
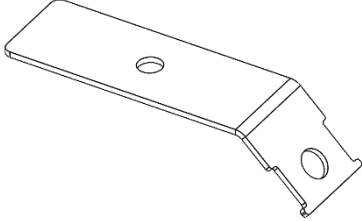
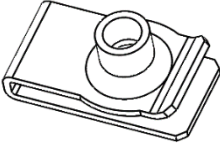
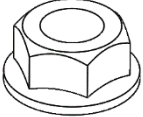
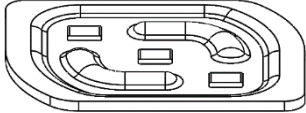
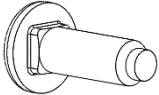
PARTS LISTING 17940020			
PART NO.	PICTURE	QTY	DESCRIPTION
3750573L		1	BLADE BRACKET RANGER LH
3750573R		1	BLADE BRACKET RANGER RH
4654979		4	MOUNTING BRACKET W/ WELD NUT
3195248		4	BLADE MOUNT PLATE
4584415		8	M8 WASHER FLAT - BONDED
5848500		4	FOAM GASKET 6.4mm
6151934		1	TORX ALLEN KEY
6151625		12	M8 X 1.25 X 25 BUTTON HEAD TORX - BLK
4581085		16	M8 WASHER FLAT - BLACK

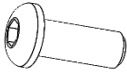
3750574		1	FRONT DIFFUSER
3750575		4	DIFFUSER MOUNT BRACKET
6151475		4	M6 U-NUT
6151132		8	M8 FLANGE NUT
3195184		8	M8 STUD PLATE
6151916		12	M8 X 25 STUD - BLACK
6151212		12	M8 X 1.25 NYLOC NUT - BLACK
4584329		4	M6 WASHER FLAT - BLACK
6151459		4	M6 BTN HEAD SCREW - BLACK
6781408		3	TAPE DOUBLE SIDED 0.8 X 15 X 300

FITTING PROCEDURE

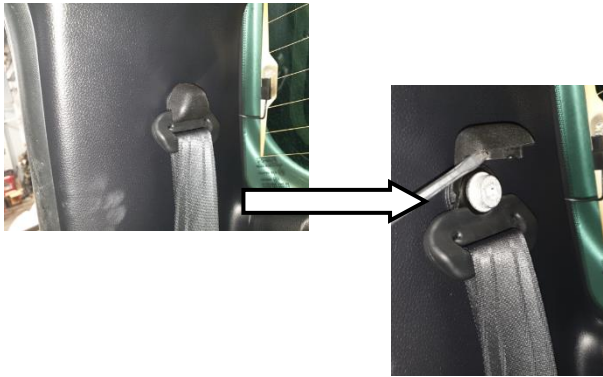

The interior roof lining needs to be released along all edges to install the cab rack kit.

Note: Ensure you retain all fasteners and clips to use when reinstalling the roof lining.

1. Remove the plastic cap to expose the retaining bolt on both rear side seat belts as shown



2. Undo the M10 torx head bolt on each side rear seat belt and remove. Allow the seatbelt to hang down as shown.



3. Pull back the door seal on the top half of the door jamb. Unclip and pull back the side rear pillar trims on both sides as shown.

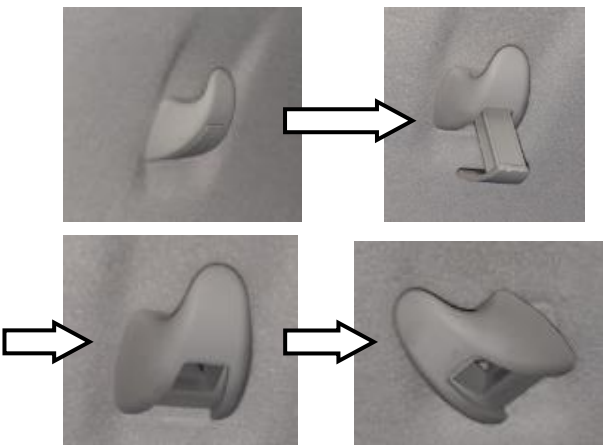

4. The hooks above the rear windscreen need to be removed. Remove the centre section, rotate 45° and carefully remove the hook from the roof lining.

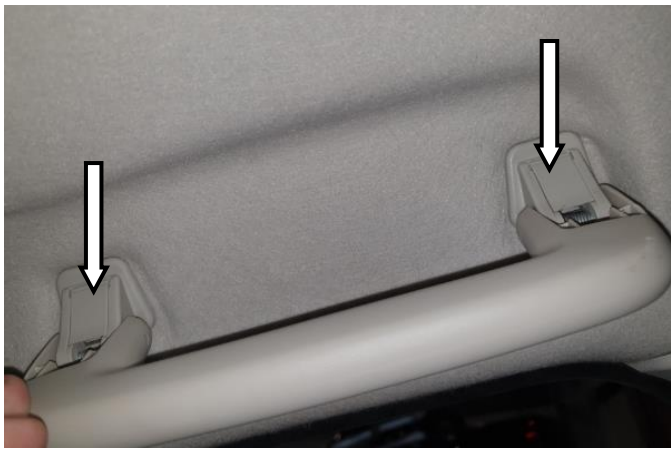

5. Remove the 4x grab handles. This is done by lifting the plastic covers to expose the torx head screws.



6. Remove the plastic cover to expose the retaining bolt on both front seat belts as shown.
Undo the Torx head bolt on each front seat belt and remove. Allow the seatbelt to hang down.



7. Pull off the door seal along the tops of front door jambs. Unclip B-pillar plastic trim on both sides.



8. Remove the grab handle on both A-pillar trims. There are two small hex bolts behind the plastic caps.



9. Both sun visors need to be removed. Remove plastic covers exposing the small torx screws.
10. Let the visors carefully hang by the wiring loom as shown.



11. Unclip the A-pillar trims.
12. The roof lining should now be free along all edges.



13. Remove the exterior roof trim from both sides of the vehicle. Take care not to bend the trim, as it will be reused.
14. Remove all remaining double-sided tape and residue glue from both the roof channels and trim. It is recommended to use an adhesive cleaner to perform this task.



15. Remove plastic covers (if fitted) located at the front pillars under the air bag positioned under the roof lining and place aside for reuse.

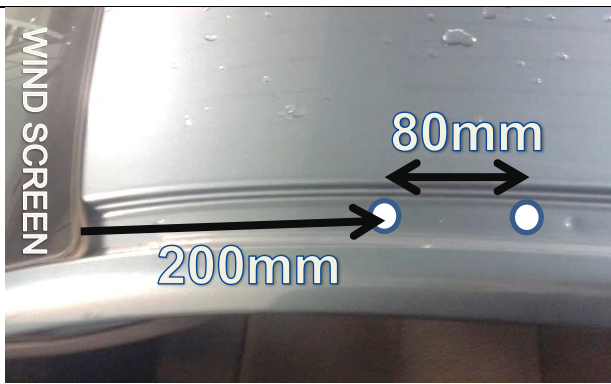

16. Using a tape measure, accurately mark point on roof channel 200mm rearward of front wind screen ensuring location marked is central between inner channel wall and edge of silicone running along outside channel wall.
 17. Mark second point on roof channel 80mm rearward of first point marked.
- Repeat steps 16 & 17 for opposite side.



18. Using a hole punch, punch at locations marked in roof channel.
 19. Using a $\Phi 9$ mm drill bit, drill stop and power drill, drill at locations marked ensuring that only 10mm of the drill bit protrudes through the roof channel so as to avoid drilling through air-bags.
- Remove all burrs and sharp edges from drilled holes and vacuum swarf.



20. Apply cold galvanising solution or rust preventative paint to cut edges of drilled holes.



21. Fit the front 2 mounting feet in the drilled holes using the M8 torx head bolts, bonded seal washers, and using foam gasket between mounting foot and roof channel as shown. Stick the foam gasket to the foot prior to mounting to the roof and carefully push the bolts through the 4mm foam gasket as shown in the LH image.





22. Carefully peeling the interior trim down, slide the reinforcement mounting plate between the air bag bracket and roof skin. Loosely fit 2x M8 flange nuts per side.



23. Loosely fit the roof blades onto the front mount feet as shown. Fit the rear feet to the blades and mark the hole positions using mount holes as a guide.

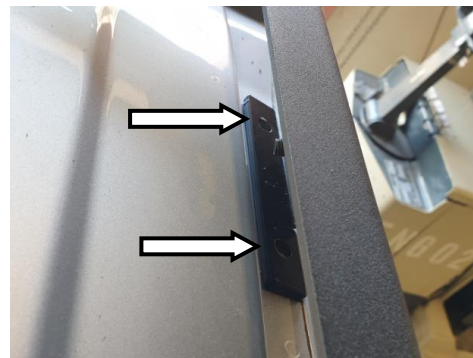

24. Remove rails and rear mounting feet from roof and punch holes at locations marked using hole punch.
25. Using a $\Phi 9\text{mm}$ drill bit, drill stop and power drill, drill at locations marked ensuring that only 10mm of the drill bit protrudes through the roof channel so as to avoid drilling into air-bags.

Remove all burrs and sharp edges from drilled holes and vacuum swarf.



26. Apply cold galvanising solution or rust preventative paint to cut edges of drilled holes.



- 27. Fit rear mounting feet as per steps 21-22. The reinforcement plates do not have to slide between any brackets. Mounting faces to be facing outwards as shown.
- 28. Tighten all 4 mounting feet to the torque specified.



 M8 - 22 Nm.



- 29. Aligning exterior roof trim removed in step 13 beside mounting feet in the roof channel, mark and then cut out sections where mounting feet are located using tin snips.
- 30. There should be six separate sections in total. Cut two pieces of double-sided tape into equal lengths of 50mm (12 pieces in total).
- 31. Apply tape to each end of the roof trim sections and position each back into roof channel.
- 32. If fitting a Roof Rack wiring kit skip to the last page before reinstalling the headliner
- 33. Reverse steps 1-12 to reinstall the roof lining and trims removed. Torque seat belt bolts to correct torque. (see page 3.)

Generic Image

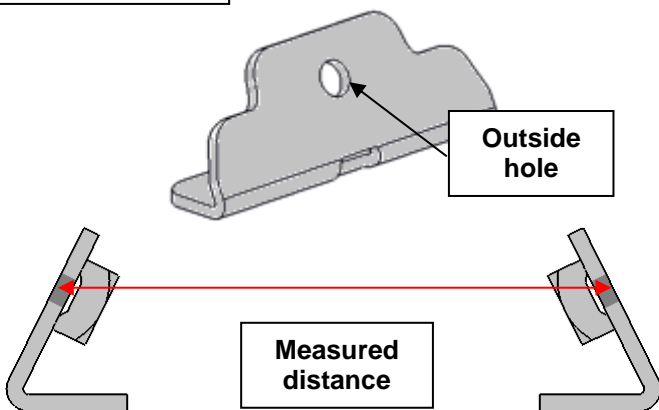

- 34. Using a tape measure, measure across the vehicle between the middle of the hole on the outside face of the front and rear set of mounting brackets. Make a note of each measurement.

Position	Distance
Front	
Rear	

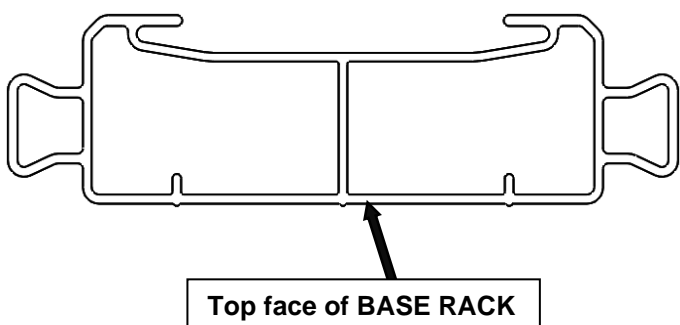

- 35. Place the BASE RACK face down on a clean flat surface. Provide protection to the top face of BASE RACK to avoid marking of surfaces

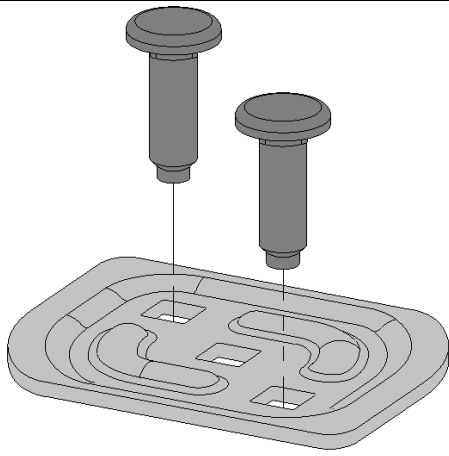

36. Insert 2, M8 x 25 Studs into 4 of the Stud Plates as shown.

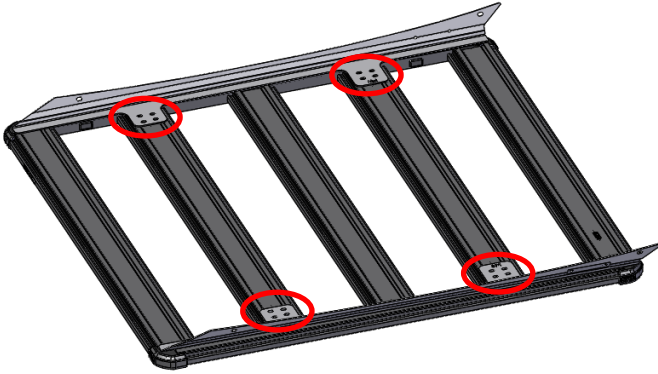

37. Check the position of the mounting plates (circled in image) on the blade brackets in relation to the channels on the BASE RACK.

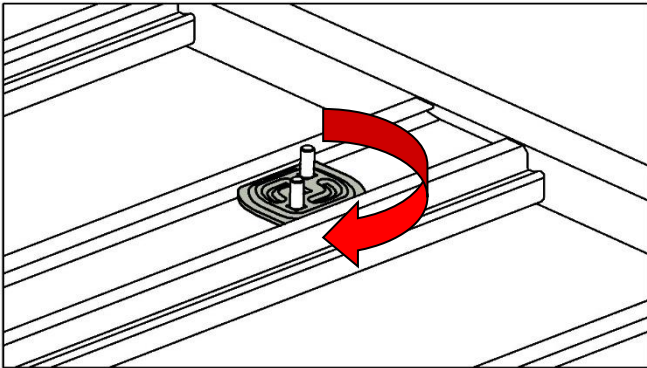

38. Insert the previously assembled stud plates into the correct BASE RACK channels. Rotate the plates 90 degrees.

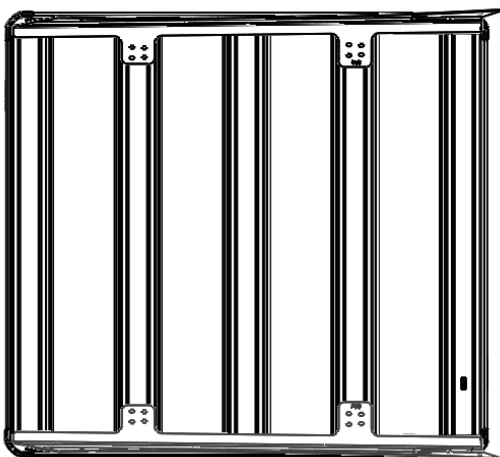
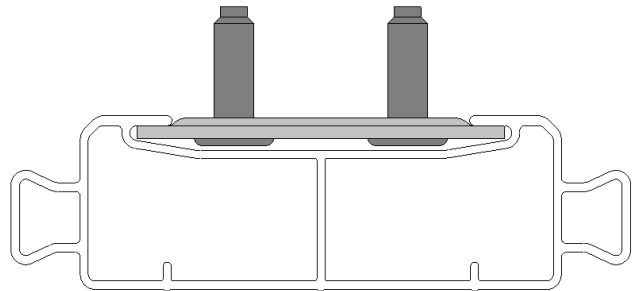

39. Flip the blade brackets over so they are upside down and carefully place on top of the BASE RACK. When doing so ensure the M8 studs in the stud plates go through the slots. Then secure the blade brackets to the BASE RACK using M8 flat washers and nyloc nuts.

Do not fully tighten, allowing each blade to move.

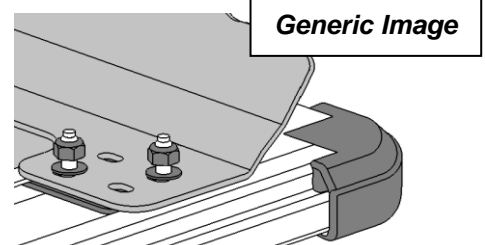

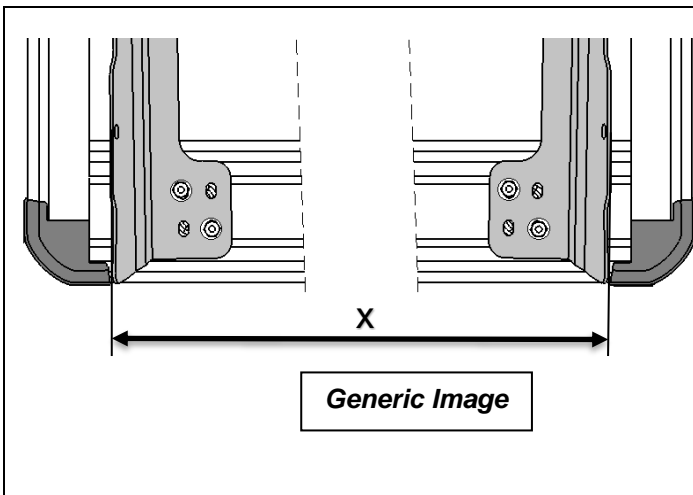

40. Using the previously recorded measurements, adjust the location of the blade bracket on the BASE RACK.
- Ensure the distance between the blade bracket and the edge of the tray is the same on both sides. Fully tighten all M8 nyloc nuts to specified torque.

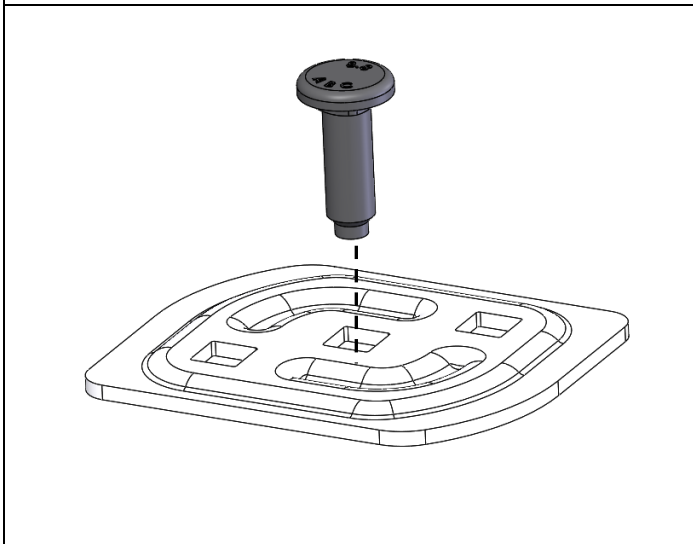
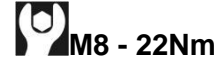

41. Insert an M8 x 25 Stud into 4 of the Stud Plates as shown.

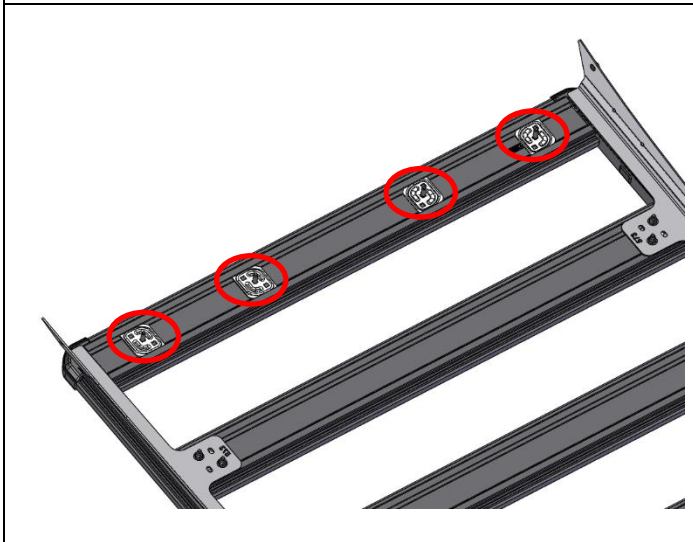

42. Insert the previously assembled stud plates into the correct BASE RACK channels. Rotate the plates 90 degrees.

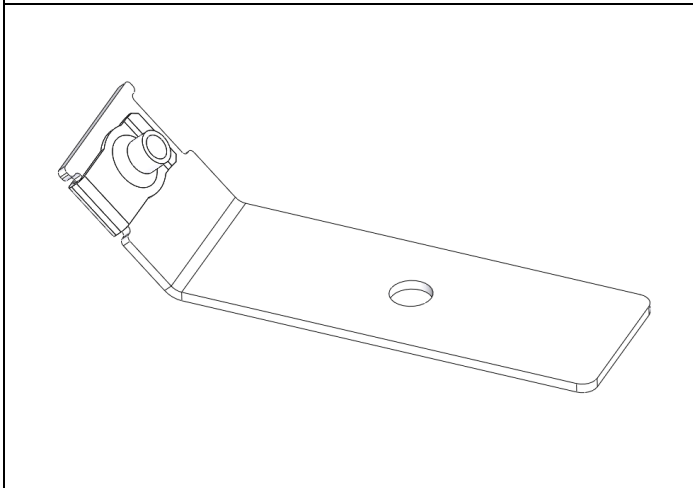
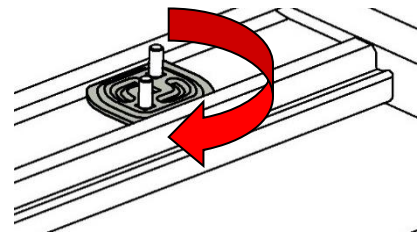

43. Fit M6 U-nuts to the 4x diffuser brackets as shown. The thread needs to be on the inside.

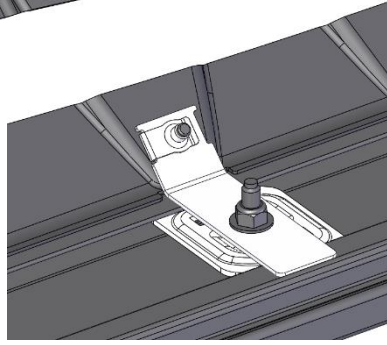
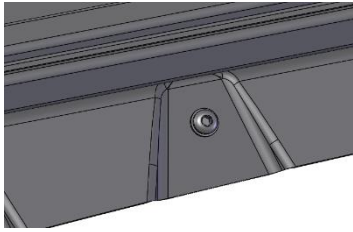

44. Loosely fit the diffuser to the mounts and brackets as shown. Use an M8 nyloc nut and washer to hold the diffuser brackets to the stud plates. Use M6 screws and washers to hold the diffuser to the brackets.
45. Tighten to specified torque.

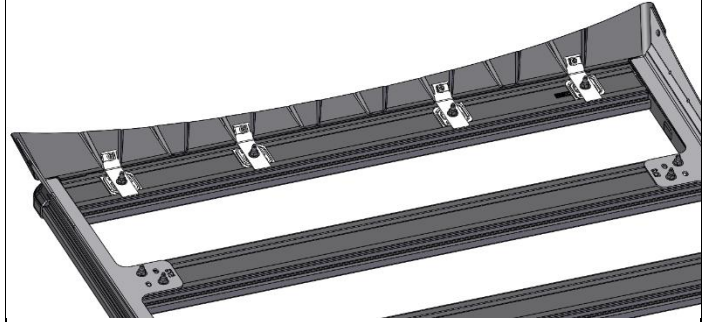

 M6 - 9Nm

 M8 - 22Nm

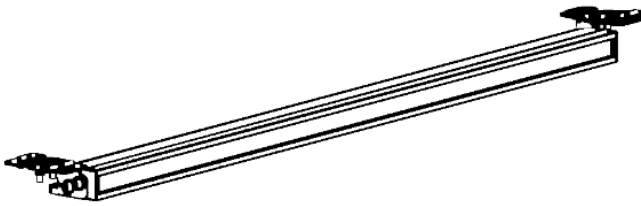

46. If fitting a BASE RACK lightbar it should be fitted to the BASE RACK at this point. Refer to instructions provided with the BASE RACK light bar for fitting details.

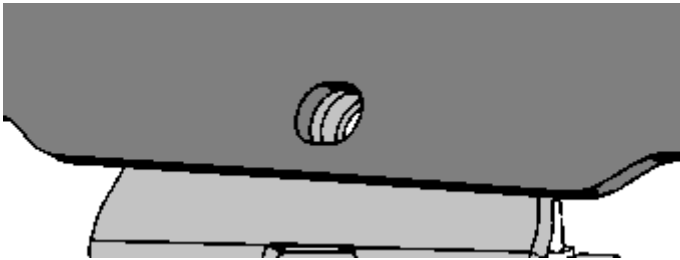

47. With assistance, carefully place the BASERACK on the vehicle so the inside of the blade brackets rests on the outside of the mounting brackets. The entire BASERACK assembly should be clear of the vehicle roof. All mounting holes/slots should align closely.

Note: Place protective material on roof to reduce the risk of accidental damage to vehicle when mounting the BASERACK to the vehicle.

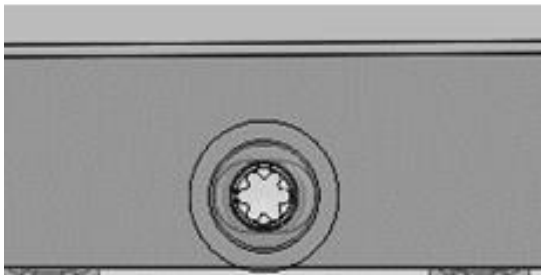

48. Confirm BASE RACK is correctly aligned to vehicle. If it is not it is recommended to remove the BASE RACK from the vehicle roof and repeat the mounting process from the measurement step #33.

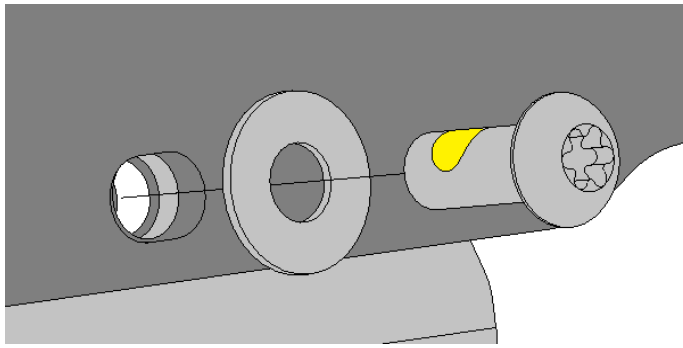

49. Use the M8 Button head Torx screws and M8 Black washers to secure the roof tray to the roof mounting brackets. Tighten all screw to the specified torque.

 M8 - 22Nm

PX & PXII aerial position shown

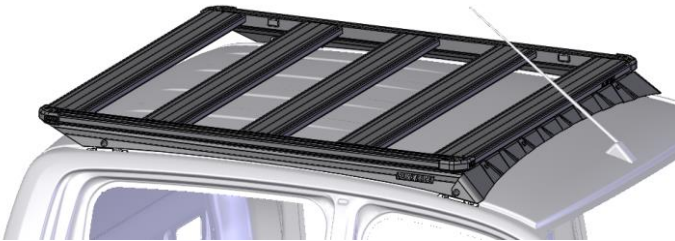

PXIII aerial position shown



FITTED PRODUCT – 2020 PXIII Ford Ranger with 1770060 Base Rack



OPTIONAL STEP FOR BASE RACK WIRING KIT

(1780400 & 1780410 SOLD SEPARATELY)

These steps are a vehicle specific supplement to the main instruction, this instruction should be used in parallel. Read and both instructions before proceeding

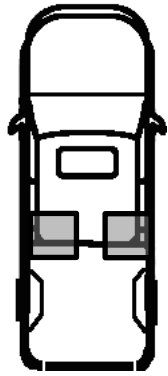

1. The recommended location for the wiring kit for this vehicle is the rear, left or right hand side
2. The location provided has been chosen to provide a safe passage away from vehicle components (airbags, vents, etc) and integrated to the rack

! CAUTION – THIS STEP MAY REQUIRE DISASSEMBLY OF SEAT BELT MOUNTS AND WORK IN THE PROXIMITY OF CURTAIN AIR BAGS !

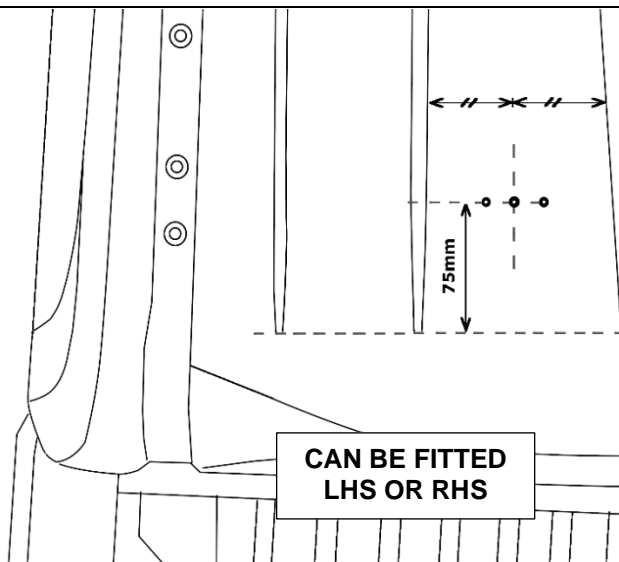

3. Mark out the hole location between the outer roof ribs as shown. Always verify they are clear inside the cabin before drilling

! CAUTION – TAKE CAUTION NOT TO DAMAGE CABLES ATTACHED TO THE INNER ROOF SKIN & ROOF LINING!



4. Run the wiring backward then follow the existing wiring loom down the rear pillar

ENSURE THE WIRING IS BEHIND THE AIRBAG

Obstruction of the airbag will prevent proper inflation and effectiveness

